

THE COMPLETE MONITORING SYSTEM that takes care of your LPG supply

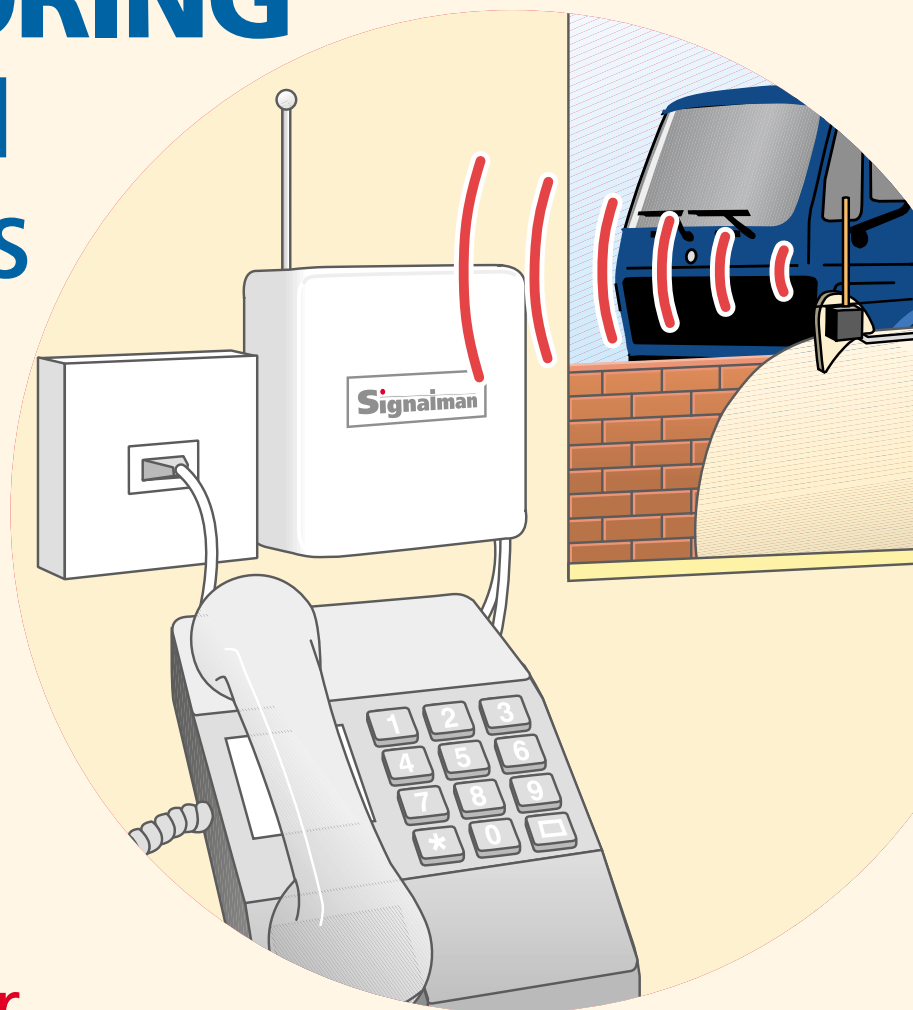

You need never
run out of LPG again

The Tank Signal System regularly checks the level in your storage tank and allows your supplier's computer to monitor it for you.

Easily installed - no wiring

Automatic system prompt for re-order

Won't interfere with telephone, fax or other appliances

BABT green dot approval for use on telephone systems

Unaffected by power cuts

Fully tested technology

Excellent reliability

TANK
Signal
SYSTEM

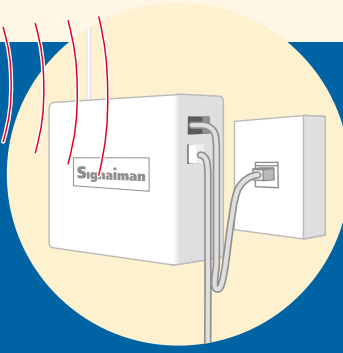
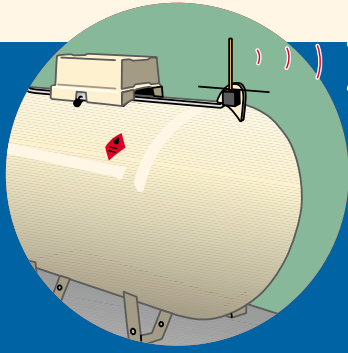

The Tank Signal System ensures that you have a dependable supply of LPG

1 A gauge reader is fitted onto your LPG tank. Using new technology it senses the level of LPG and its small transmitter sends this information out by regular radio signals up to 1,000 metres, right into your premises.

2 Your Signalman shares a phone or fax line. It receives the signals and, when the line is not in use, reports the level to a computer in your LPG supplier's premises.

3 Now, for the first time, your supplier can check whether your fuel level is running low, and arrange a delivery with you to ensure that you never run out of LPG.

The Signalman reports the LPG level to your supplier so that he can arrange to top up your tank. No fuss, no delay – you don't have to do a thing.

Sensor Systems are proud to support these trade organisations and to have received these awards and approvals:



ALGED
Association of Liquid Gas &
Equipment Distributors UK

LP GAS
— Association Member



Sensor Systems Watchman Ltd
Shaerf Drive, Lurgan,
County Armagh,
Northern Ireland BT66 8DD
Telephone: +44 (0)2838 321111
Facsimile: +44 (0)2838 324444
Email: sales@sensor-systems.com
Website: <http://www.sensor-systems.com>

Remote control by

Sensor
systems